

C-K ENGINEERING, INC.

Providing advanced internal engine design and measurement concepts

PROMPT

Piston and Ring Optimizing Model for Performance Technology

Key Features:

- Windows-based program with a tree interface for selecting desired data entry screens
- Ability to consider approximately forty input variables including ring face profiles, ring cross sections, and piston land geometries
- Modeling of ring conformability to permit ring-to-bore orifice areas and pressure variations to be considered
- Modeling of two-piece and three-piece oil rings
- Calculation and display of specific outputs
- Gas flow – positive and negative
- Ring movement
- Ring force – top/bottom of groove
- Ring twist
- Oil film thickness
- Friction – individual rings

Oil Flow Paths

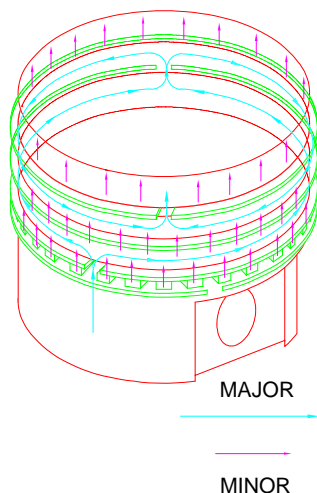

Minimum Recommended Hardware Requirements:

- 200 MHz Pentium computer
- 32 MB RAM
- 4 GB hard disk drive
 - 21 MB for program files
 - 4-21 MB per analysis
- Super VGA monitor (17")

PROMPT is a state-of-the-art Windows-based cylinder kit analysis model. Cylinder kit dimensional data is entered through use of an input tree to access data entry screens. Default values are available for use in cases where complete data may not be available. However, use of default values may decrease the precision of results.

PROMPT is a fourth-generation cylinder kit model that has evolved over thirty years of effort to develop an effective analysis and methodology to understand the effect of more than forty dimensional variables on cylinder kit performance.

By using combustion pressure data from an engine at the speed and load conditions under consideration, the PROMPT model can be used to optimize mean value, tolerance, and relationships among the variables.

The model considers the total effective orifice area for top, second, and oil rings. The total effective orifice area is comprised of the three orifice areas shown below:

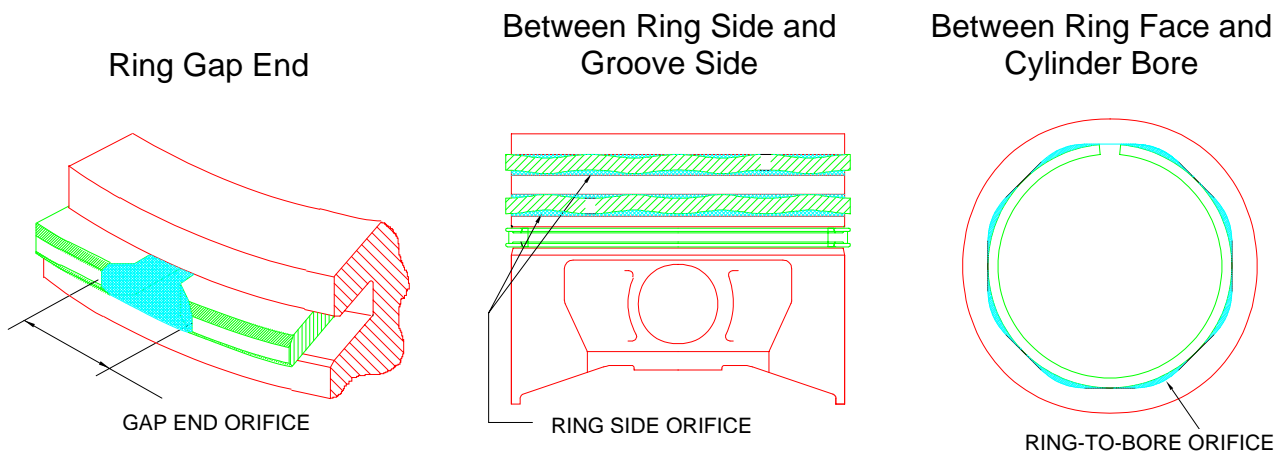

This basic model and its related methodology for planning the study and reducing the resultant data have been successfully applied to improve the performance of:

- Small industrial/lawn mower engines
- Automotive engines
- Diesel engines ranging in size from a few horsepower to several thousand horsepower
- High-performance (race) engines

In order to achieve this improved performance, the model utilizes entered cylinder kit geometry data and the combustion pressure diagram developed in the engine at the speed and load conditions of interest.

The model treats the cylinder kit as a series of orifices/accumulator volumes to calculate:

- Blowby (quantitatively)
- Oil consumption (qualitatively)
- Friction (quantitatively)
- Hydrocarbon emissions

Design of Experiments (DOE) has been utilized to effectively plan studies considering as many as twelve of the possible variables and evaluate their effect on oil consumption, blowby, and friction. Typical summary plots for a system that provides a ranking of the importance of each variable studied is shown below:

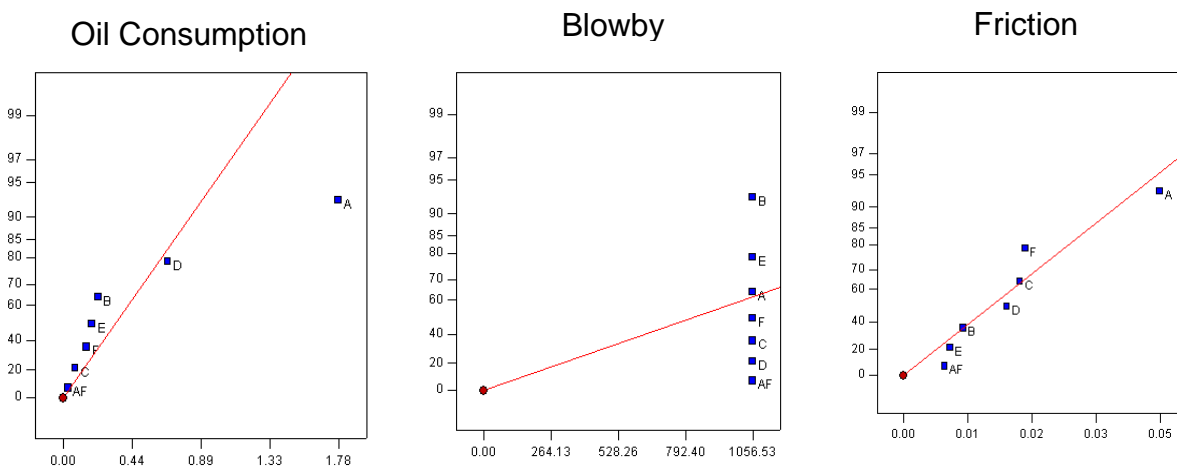

Factors affecting oil control, blowby, and friction include:

- Engine load
- Engine speed
- Piston top land diameter
- Piston top land width
- Piston top ring groove width
- Piston top groove root diameter
- Top ring width
- Top ring radial wall
- Top ring end clearance
- Top ring chamfer size at gap end
- Top ring non-flatness (twist)
- Top ring groove non-flatness
- Top ring void area ring face to cylinder bore
- Top ring face profile
- Piston second land diameter
- Piston second land OD corner chamfer
- Piston second ring groove width
- Piston second ring groove root diameter
- Second ring width
- Second ring radial wall
- Second ring end clearance
- Second ring chamfer size at gap end
- Second ring groove non-flatness
- Second ring void area ring face to cylinder bore
- Second ring tension
- Second ring material modulus
- Second ring free shape
- Piston third land diameter
- Piston third land OD corner chamfer beneath second ring groove
- Oil ring width
- Oil ring radial wall
- Oil ring gap end chamfer size
- Oil ring groove non-flatness
- Oil ring void area ring face to cylinder bore
- Oil ring tension
- Oil ring material modulus
- Oil ring expander load and distribution
- Oil ring face profile
- Oil ring drainback area
- Piston land diameter beneath oil ring
- Cylinder bore geometry
- Cylinder bore finish
- Crankcase pressure/vacuum
- Side sealing forces
- Piston movement
- Engine design

For additional information on this and cylinder component gage designs, please contact us at:

C-K Engineering, Inc.; 116 Holloway Road; Ballwin, MO 63011

Phone: 636/394-3331; Fax: 636/394-5844; Email: ckenginc@aol.com; Website: www.c-kengineering.com